



EVERPURE® QC7I SINGLE - MC² SYSTEM

FILTER HEAD EXCLUSIVELY FOR EVERPURE REPLACEMENT CARTRIDGES

QC7I Single - MC² System: EV9275-01
MC2 Replacement Cartridge: EV9612-56



APPLICATIONS

Fountain Beverage
For Most Single-Carbonator Dispensers
Dispensers Using Up To 25 Tanks Of Syrup
or Bag-In-Box Per Month

FEATURES • BENEFITS

Improves the taste of fountain beverages and helps retain the drink's carbonation

Sanitary cartridge replacement is simple, quick and clean. Internal filter parts are never exposed to handling or contamination

Proprietary Micro-Pure® II filtration media effectively inhibits the growth of bacteria on the filter media that can decrease the life of the product

Protects drink system seals, pump, tubing and small orifices from clogging, corrosion and abrasive wear

Exclusive precoat filtration provides superior chlorine taste & odor reduction and micro-filters dirt and particles as small as 0.2* micron in size by mechanical means

Reduces chlorine taste & odor and other offensive contaminants that can adversely affect the taste of beverages

NSF/ANSI Standard 53 certified to reduce cysts such as *Cryptosporidium* and *Giardia* by mechanical means

* Validated by ISO 17025 accredited lab for 99.999% reduction of *Pseudomonas diminuta* following the ASTM F838-05 protocol for the validation of 0.2 µm sterilizing grade filters.

INSTALLATION TIPS

Never use saddle valve for connection.

Use 3/8" water line.

Install vertically with cartridge hanging down.

Allow 2 1/2" (6.35 cm) clearance below the cartridge for easy cartridge replacement.

Flush cartridge by running water through system for five (5) minutes at full flow.

OPERATION TIPS

Change cartridges on a regular six (6) month preventative maintenance program.

Change cartridges when capacity is reached or when pressure falls below 10 psi (0.7 bar).

Service flow rate must not exceed 1.67 gpm (6.3 Lpm).

Always flush the filter cartridge at time of installation and cartridge change.

SIZING

Service Flow Rate: Maximum 1.67 gpm (6.3 Lpm)

Rated Capacity: 9,000 gallons (35,069 L)

EVERPURE® QC7I SINGLE - MC² SYSTEM

EV9275-01

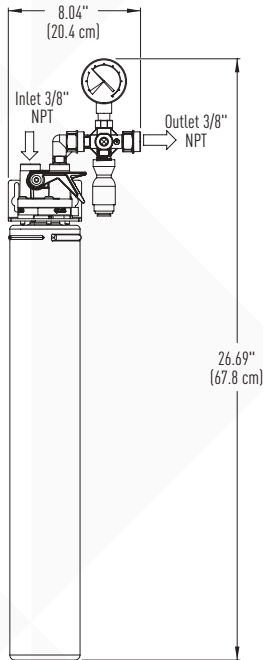

EPA Est. No. 002623-IL-002

The contaminants or other substances removed or reduced by this drinking water system are not necessarily in your water. Do not use with water that is microbiologically unsafe or of unknown quality without adequate disinfection before or after the system. Systems certified for cyst reduction may be used with disinfected water that may contain filterable cysts.

Since the conditions under which our products may be used are beyond our control, we cannot accept any liability with respect to the improper installation, application and/or use of our products.

SPECIFICATIONS

Service Flow Rate

Maximum 1.67 gpm (6.3 Lpm)

Rated Capacity

9,000 gallons (35,069 L)

Pressure Requirements

10 – 125 psi (0.7 – 8.6 bar), non-shock

Temperature

35 – 100°F (2 – 38°C)

Overall Dimensions

26.69" H x 8.04" W x 5.25" D
(67.8 cm x 20.4 cm x 13.3 cm)

Inlet Connection

3/8"

Outlet Connection

3/8"

Electrical Connection

None required

Shipping Weight

7 lbs (3.1 kgs)

Operating Weight:

8 lbs (3.6 kgs)



System Tested and Certified by NSF International against NSF/ANSI Standards 42 and 53 for the reduction of:

STANDARD NO. 42 –
AESTHETIC EFFECTS

Chemical Reduction
Taste & Odor
Chlorine

Mechanical Filtration
Nominal Particulate Class I

STANDARD NO. 53 –
HEALTH EFFECTS

Mechanical Filtration
Cyst

WARRANTY

Everpure water treatment systems by Pentair® (excluding replaceable elements) are covered by a limited warranty against defects in material and workmanship for a period of five years after date of purchase. Everpure replaceable elements (filter cartridges and water treatment cartridges) are covered by a limited warranty against defects in material and workmanship for a period of one year after date of purchase. See printed warranty for details. Pentair will provide a copy of the warranty upon request.



WATER QUALITY SYSTEMS

EVERPURE-SHURFLO WORLD HEADQUARTERS, 1040 MUIRFIELD DRIVE, HANOVER PARK, IL 60133 USA • FOODSERVICE.PENTAIR.COM
800.942.1153 (US ONLY) • 630.307.3000 MAIN • 630.307.3030 FAX • CSEVERPURE@PENTAIR.COM EMAIL

EVERPURE-SHURFLO AUSTRALIA, 1-21 MONASH DRIVE, DANDENONG SOUTH, VIC 3175 AUSTRALIA
011.1300.576.190 TEL • 011.61.39.562.7237 FAX • AU.EVERPURE@PENTAIR.COM EMAIL

EVERPURE-SHURFLO CHINA, 21F CLOUD 9 PLAZA, NO 1118, SHANGHAI, 200052, CHINA
86.21.3211.4588 TEL • 86.21.3211.4580 FAX • CHINA.WATER@PENTAIR.COM EMAIL

EVERPURE-SHURFLO INDIA, GREEN BOULEVARD, B-9/A, 7TH FLOOR - TOWER B SECTOR 62, NOIDA - 201301
91.120.419.9444 TEL • 91.120.419.9400 FAX • INDIACUSTOMER@PENTAIR.COM EMAIL

EVERPURE-SHURFLO EUROPE, PENTAIR WATER BELGIUM BVBA, INDUSTRIEPARK WOLFSTEE, TOEKOMSTLAAN 30, B-2200 HERENTALS, BELGIUM
+32.(0).14.283.504 TEL • +32.(0).14.283.505 FAX • SALES@EVERPURE-EUROPE.COM EMAIL

EVERPURE-SHURFLO JAPAN INC., HASHIMOTO MN BLDG. 7F, 3-25-1 HASHIMOTO, MIDORI-KU, SAGAMIHARA-SHI KANAGAWA 252-0143, JAPAN
81.(0)42.775.3011 TEL • 81.(0)42.775.3015 FAX • INFO@EVERPURE.CO.JP EMAIL

EVERPURE-SHURFLO SOUTHEAST ASIA, 390 HAVELOCK ROAD, #04-01 KING'S CENTRE, SINGAPORE 169662
65.6768.5800 TEL • 65.6737.5149 FAX • CSEVERPURE@PENTAIR.COM EMAIL

All Pentair trademarks and logos are owned by Pentair, Inc. or its affiliates. All other registered and unregistered trademarks and logos are the property of their respective owners. Because we are continuously improving our products and services, Pentair reserves the right to change specifications without prior notice. Pentair is an equal opportunity employer.



EVERPURE® COLDRINK® 1-MC² SYSTEM

DELIVERS PREMIUM QUALITY WATER FOR FOUNTAIN APPLICATIONS

Coldrink 1-MC² System: EV9328-01
MC² Replacement Cartridge: EV9612-56
EC210 Prefilter Cartridge: EV9534-26



APPLICATIONS

Fountain Beverage
Single-Carbonator Dispensers

Dispensers Using Up To 25 Tanks Of Syrup
or Bag-In-Box Per Month

FEATURES • BENEFITS

Improves the taste of fountain beverages and helps retain the drink's carbonation

Sanitary cartridge replacement is simple, quick and clean; internal filter parts are never exposed to handling or contamination

Protects drink system seals, pump, tubing and small orifices from clogging, corrosion and abrasive wear

Proprietary Micro-Pure® II filtration media effectively inhibits the growth of bacteria on the filter media that can decrease product life

Exclusive precoat filtration provides superior chlorine taste & odor reduction and micro-filters dirt and particles as small as 0.2* micron in size by mechanical means

Reduces chlorine taste & odor and other offensive contaminants

Plated mounted system allows for easy installation and startup

20" prefilter reduces dirt and particles

NSF/ANSI Standard 53 certified to reduce cysts such as *Cryptosporidium* and *Giardia* by mechanical means

* Validated by ISO 17025 accredited lab for 99.999% reduction of *Pseudomonas diminuta* following the ASTM F838-05 protocol for the validation of 0.2 µm sterilizing grade filters

INSTALLATION TIPS

Choose a mounting location suitable to support the full weight of the system when operating.

Never use saddle valve for connection.

Use 3/4" water line.

Install vertically with cartridges hanging down.

Allow 2 1/2" (6.35 cm) clearance below the cartridge for easy cartridge replacement.

Flush cartridges by running water through system for five (5) minutes at full flow.

OPERATION TIPS

Change cartridges on a regular six (6) month preventative maintenance program.

Change cartridges when capacity is reached or when pressure falls below 10 psi (0.7 bar).

Always flush the filter cartridge at time of installation and cartridge change.

Inspect Everpure EC210 Cartridge periodically to determine dirt load.

Replace Everpure EC210 Cartridge when dirt has penetrated through to the inner core of the cartridge.

SIZING

Service Flow Rate: Maximum 1.67 gpm (6.3 Lpm)

Capacity: 9,000 gallons (35,069 L)

EVERPURE® COLDRINK® 1-MC² SYSTEM

EV9328-01

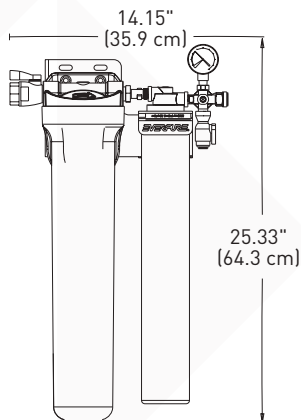

SPECIFICATIONS

Rated Capacity

9,000 gallons (35,069 L)

Service Flow Rate

Maximum 1.67 gpm (6.3 Lpm)

Pressure Requirements

10–125 psi (0.7–8.6 bar), non-shock

Temperature

35–100°F (2–38°C)

Overall Dimensions

25.33" H x 14.15" W x 6.74" D
(64.3 cm x 35.9 cm x 17.1 cm)

Inlet Connection

3/4"

Outlet Connection

3/4"

Operating Weight

19 lbs (8.6 kgs)

Shipping Weight

10 lbs (4.5 kgs)

Electrical Connection

None required



System Tested and Certified by NSF International against NSF/ANSI Standards 42 and 53 for the reduction of:

STANDARD NO. 42 –
AESTHETIC EFFECTS

Chemical Reduction
Taste & Odor
Chlorine

Mechanical Filtration
Nominal Particulate Class I

STANDARD NO. 53 –
HEALTH EFFECTS

Mechanical Filtration
Cyst

EPA Est. No. 002623-IL-002

The contaminants or other substances removed or reduced by this drinking water system are not necessarily in your water. Do not use with water that is microbiologically unsafe or of unknown quality without adequate disinfection before or after the system. Systems certified for cyst reduction may be used with disinfected water that may contain filterable cysts.

Since the conditions under which our products may be used are beyond our control, we cannot accept any liability with respect to the improper installation, application and/or use of our products.

WARRANTY

Everpure water treatment systems by Pentair® (excluding replaceable elements) are covered by a limited warranty against defects in material and workmanship for a period of five years after date of purchase. Everpure replaceable elements (filter cartridges and water treatment cartridges) are covered by a limited warranty against defects in material and workmanship for a period of one year after date of purchase. See printed warranty for details. Pentair will provide a copy of the warranty upon request.



WATER QUALITY SYSTEMS

EVERPURE-SHURFLO WORLD HEADQUARTERS, 1040 MUIRFIELD DRIVE, HANOVER PARK, IL 60133 USA • FOODSERVICE.PENTAIR.COM
800.942.1153 (US ONLY) • 630.307.3000 MAIN • 630.307.3030 FAX • CSEVERPURE@PENTAIR.COM EMAIL

EVERPURE-SHURFLO AUSTRALIA, 1-21 MONASH DRIVE, DANDENONG SOUTH, VIC 3175 AUSTRALIA
011.1300 576 190 TEL • 011.61.39.562.7237 FAX • AU.EVERPURE@PENTAIR.COM EMAIL

EVERPURE-SHURFLO CHINA, 21F CLOUD 9 PLAZA, NO 1118, SHANGHAI, 200052, CHINA
86.21.3211.4588 TEL • 86.21.3211.4580 FAX • CHINA.WATER@PENTAIR.COM EMAIL

EVERPURE-SHURFLO INDIA, GREEN BOULEVARD, B-9/A, 7TH FLOOR - TOWER B SECTOR 62, NOIDA - 201301
91.120.419.9444 TEL • 91.120.419.9400 FAX • INDIACUSTOMER@PENTAIR.COM EMAIL

EVERPURE-SHURFLO EUROPE, PENTAIR WATER BELGIUM BVBA, INDUSTRIEPARK WOLFSTEE, TOEKOMSTLAAN 30, B-2200 HERENTALS, BELGIUM
+32.(0).14.283.504 TEL • +32.(0).14.283.505 FAX • SALES@EVERPURE-EUROPE.COM EMAIL

EVERPURE-SHURFLO JAPAN INC., HASHIMOTO MN BLDG. 7F, 3-25-1 HASHIMOTO, MIDORI-KU, SAGAMIHARA-SHI KANAGAWA 252-0143, JAPAN
81.(0)42.775.3011 TEL • 81.(0)42.775.3015 FAX • INFO@EVERPURE.CO.JP EMAIL

EVERPURE-SHURFLO SOUTHEAST ASIA, 390 HAVELOCK ROAD, #04-01 KING'S CENTRE, SINGAPORE 169662
65.6768.5800 TEL • 65.6737.5149 FAX • CSEVERPURE@PENTAIR.COM EMAIL

All Pentair trademarks and logos are owned by Pentair, Inc. or its affiliates. All other registered and unregistered trademarks and logos are the property of their respective owners. Because we are continuously improving our products and services, Pentair reserves the right to change specifications without prior notice. Pentair is an equal opportunity employer.



EVERPURE® COLDRINK® 2-MC² SYSTEM

DELIVERS PREMIUM QUALITY WATER FOR FOUNTAIN APPLICATIONS

Coldrink 2-MC² System: EV9328-02
MC² Replacement Cartridge: EV9612-56
EC210 Prefilter Cartridge: EV9534-26



APPLICATIONS

Fountain
Single-Carbonator Dispensers

Dispensers Using Up To 50 Tanks Of Syrup
or Bag-In-Box Per Month

FEATURES • BENEFITS

Improves the taste of fountain beverages and helps retain the drink's carbonation

Sanitary cartridge replacement is simple, quick and clean; internal filter parts are never exposed to handling or contamination

Protects drink system seals, pump, tubing and small orifices from clogging, corrosion and abrasive wear

Proprietary Micro-Pure® II filtration media effectively inhibits the growth of bacteria on the filter media that can decrease product life

Exclusive precoat filtration provides superior chlorine taste & odor reduction and micro-filters dirt and particles as small as 0.2* micron in size by mechanical means

Reduces chlorine taste & odor and other offensive contaminants

Manifold features water shut-off, flushing valve, inlet and outlet pressure gauges

20" prefilter reduces dirt and particles

NSF/ANSI Standard 53 certified to reduce cysts such as *Cryptosporidium* and *Giardia* by mechanical means

* Validated by ISO 17025 accredited lab for 99.999% reduction of *Pseudomonas diminuta* following the ASTM F838-05 protocol for the validation of 0.2 µm sterilizing grade filters.

INSTALLATION TIPS

Choose a mounting location suitable to support the full weight of the system when operating.

Never use saddle valve for connection.

Use 3/4" water line.

Install vertically with cartridges hanging down.

Allow 2½" (6.35 cm) clearance below the cartridge for easy cartridge replacement.

Flush cartridges by running water through system for five (5) minutes at full flow.

OPERATION TIPS

Change cartridges on a regular six (6) month preventative maintenance program.

Change cartridges when capacity is reached or when pressure falls below 10 psi (0.7 bar).

Always flush the filter cartridge at time of installation and cartridge change.

Inspect Everpure EC210 Cartridge periodically to determine dirt load.

Replace Everpure EC210 Cartridge when dirt has penetrated through to the inner core of the cartridge.

SIZING

Rated Capacity: 18,000 gallons (68,137.4 L)

Service Flow Rate: Maximum 3.34 gpm (12.6 Lpm)

EVERPURE® COLDRINK® 2-MC² SYSTEM

EV9328-02

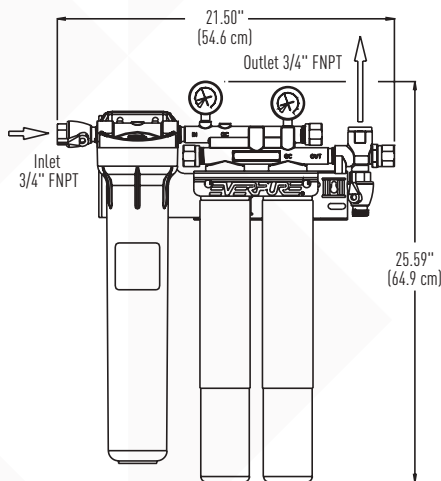

SPECIFICATIONS

Service Flow Rate

Maximum 3.34 gpm (12.6 Lpm)

Rated Capacity:

18,000 gallons (68,137.4 L)

Pressure Requirements

10–125 psi (0.7–8.6 bar), non-shock

Temperature

35–100°F (2–38°C)

Overall Dimensions

25.59" H x 21.5" W x 6" D
(64.9 cm x 54.6 cm x 15.2 cm)

Inlet Connection

3/4"

Outlet Connection

3/4"

Shipping Weight

20 lbs (9 kgs)

Operating Weight

29 lbs 13.1 kgs)

Electrical Connection

None required



System Tested and Certified by NSF International against NSF/ANSI Standards 42 and 53 for the reduction of:

STANDARD NO. 42 –
AESTHETIC EFFECTS

Chemical Reduction
Taste & Odor
Chlorine

Mechanical Filtration
Nominal Particulate Class I

STANDARD NO. 53 –
HEALTH EFFECTS

Mechanical Filtration
Cyst

EPA Est. No. 002623-IL-002

The contaminants or other substances removed or reduced by this drinking water system are not necessarily in your water. Do not use with water that is microbiologically unsafe or of unknown quality without adequate disinfection before or after the system. Systems certified for cyst reduction may be used with disinfected water that may contain filterable cysts.

Since the conditions under which our products may be used are beyond our control, we cannot accept any liability with respect to the improper installation, application and/or use of our products.

WARRANTY

Everpure water treatment systems by Pentair® (excluding replaceable elements) are covered by a limited warranty against defects in material and workmanship for a period of five years after date of purchase. Everpure replaceable elements (filter cartridges and water treatment cartridges) are covered by a limited warranty against defects in material and workmanship for a period of one year after date of purchase. See printed warranty for details. Pentair will provide a copy of the warranty upon request.



WATER QUALITY SYSTEMS

EVERPURE-SHURFLO WORLD HEADQUARTERS, 1040 MUIRFIELD DRIVE, HANOVER PARK, IL 60133 USA • FOODSERVICE.PENTAIR.COM
800.942.1153 (US ONLY) • 630.307.3000 MAIN • 630.307.3030 FAX • CSEVERPURE@PENTAIR.COM EMAIL

EVERPURE-SHURFLO AUSTRALIA, 1-21 MONASH DRIVE, DANDENONG SOUTH, VIC 3175 AUSTRALIA
011.1300.576.190 TEL • 011.61.39.562.7237 FAX • AU.EVERPURE@PENTAIR.COM EMAIL

EVERPURE-SHURFLO CHINA, 21F CLOUD 9 PLAZA, NO 1118, SHANGHAI, 200052, CHINA
86.21.3211.4588 TEL • 86.21.3211.4580 FAX • CHINA.WATER@PENTAIR.COM EMAIL

EVERPURE-SHURFLO INDIA, GREEN BOULEVARD, B-9/A, 7TH FLOOR - TOWER B SECTOR 62, NOIDA - 201301
91.120.419.9444 TEL • 91.120.419.9400 FAX • INDIACUSTOMER@PENTAIR.COM EMAIL

EVERPURE-SHURFLO EUROPE, PENTAIR WATER BELGIUM BVBA, INDUSTRIEPARK WOLFSTEE, TOEKOMSTLAAN 30, B-2200 HERENTALS, BELGIUM
+32.(0).14.283.504 TEL • +32.(0).14.283.505 FAX • SALES@EVERPURE-EUROPE.COM EMAIL

EVERPURE-SHURFLO JAPAN INC., HASHIMOTO MN BLDG. 7F, 3-25-1 HASHIMOTO, MIDORI-KU, SAGAMIHARA-SHI KANAGAWA 252-0143, JAPAN
81.(0)42.775.3011 TEL • 81.(0)42.775.3015 FAX • INFO@EVERPURE.CO.JP EMAIL

EVERPURE-SHURFLO SOUTHEAST ASIA, 390 HAVELOCK ROAD, #04-01 KING'S CENTRE, SINGAPORE 169662
65.6768.5800 TEL • 65.6737.5149 FAX • CSEVERPURE@PENTAIR.COM EMAIL

All Pentair trademarks and logos are owned by Pentair, Inc. or its affiliates. All other registered and unregistered trademarks and logos are the property of their respective owners. Because we are continuously improving our products and services, Pentair reserves the right to change specifications without prior notice. Pentair is an equal opportunity employer.



EVERPURE® COLDRINK® 3-MC² SYSTEM

DELIVERS PREMIUM QUALITY WATER FOR FOUNTAIN APPLICATIONS

Coldrink 3-MC² System: EV9328-03
MC² Replacement Cartridge: EV9612-56
EC210 Prefilter Cartridge: EV9534-26



APPLICATIONS

Fountain Beverages
For Most Dual-Carbonator Dispensers

Dispensers Using Up To 50 Tanks Of Syrup
or Bag-In-Box Per Month

FEATURES • BENEFITS

Improves the taste of fountain beverages and helps retain the drink's carbonation

Sanitary cartridge replacement is simple, quick and clean; internal filter parts are never exposed to handling or contamination

Protects drink system seals, pump, tubing and small orifices from clogging, corrosion and abrasive wear

Proprietary Micro-Pure® II filtration media effectively inhibits the growth of bacteria on the filter media that can decrease product life

Exclusive precoat filtration provides superior chlorine taste & odor reduction and micro-filters dirt and particles as small as 0.2* micron in size by mechanical means

Reduces chlorine taste & odor and other offensive contaminants

Manifold features water shut-off, flushing valve, inlet and outlet pressure gauges

20" prefilter reduces dirt and particles

NSF/ANSI Standard 53 certified to reduce cysts such as *Cryptosporidium* and *Giardia* by mechanical means

* Validated by ISO 17025 accredited lab for 99.999% reduction of *Pseudomonas diminuta* following the ASTM F838-05 protocol for the validation of 0.2 µm sterilizing grade filters.

INSTALLATION TIPS

Choose a mounting location suitable to support the full weight of the system when operating.

Never use saddle valve for connection.

Use 3/4" water line.

Install vertically with cartridges hanging down.

Allow 2 1/2" (6.35 cm) clearance below the cartridge for easy cartridge replacement.

Flush cartridges by running water through system for five (5) minutes at full flow.

OPERATION TIPS

Change cartridges on a regular six (6) month preventative maintenance program.

Change cartridges when capacity is reached or when pressure falls below 10 psi (0.7 bar).

Always flush the filter cartridge at time of installation and cartridge change.

Inspect Everpure EC210 Cartridge periodically to determine dirt load.

Replace Everpure EC210 Cartridge when dirt has penetrated through to the inner core of the cartridge.

SIZING

Service Flow Rate: Maximum 5 gpm (18.9 Lpm)

Capacity: 27,000 gallons (102,206 L)

EVERPURE® COLDRINK® 3-MC² SYSTEM

EV9328-03

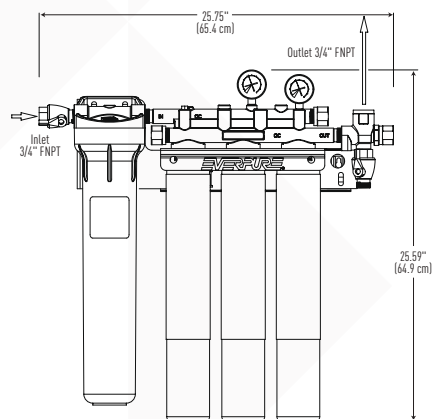

SPECIFICATIONS

Service Flow Rate

Maximum 5 gpm (18.9 Lpm)

Rated Capacity

27,000 gallons (102,206 L)

Pressure Requirements

10 - 125 psi (0.7 - 8.6 bar), non-shock

Temperature

35 - 100°F (2 - 38°C)

Overall Dimensions

25.59" L x 25.75" W x 6" D
(64.9 cm x 65.4 cm x 15.2 cm)

Inlet Connection

3/4"

Outlet Connection

3/4"

Operating Weight

35 lbs (15.8 kg)

Shipping Weight

23 lbs (10.4 kg)

Electrical Connection

None required



System Tested and Certified by NSF International against NSF/ANSI Standards 42 and 53 for the reduction of:

STANDARD NO. 42 –
AESTHETIC EFFECTS

Chemical Reduction
Taste & Odor
Chlorine

Mechanical Filtration
Nominal Particulate Class I

STANDARD NO. 53 –
HEALTH EFFECTS

Mechanical Filtration
Cyst

EPA Est. No. 002623-IL-002

The contaminants or other substances removed or reduced by this drinking water system are not necessarily in your water. Do not use with water that is microbiologically unsafe or of unknown quality without adequate disinfection before or after the system. Systems certified for cyst reduction may be used with disinfected water that may contain filterable cysts.

Since the conditions under which our products may be used are beyond our control, we cannot accept any liability with respect to the improper installation, application and/ or use of our products.

WARRANTY

Everpure water treatment systems by Pentair® (excluding replaceable elements) are covered by a limited warranty against defects in material and workmanship for a period of five years after date of purchase. Everpure replaceable elements (filter cartridges and water treatment cartridges) are covered by a limited warranty against defects in material and workmanship for a period of one year after date of purchase. See printed warranty for details. Pentair will provide a copy of the warranty upon request.



WATER QUALITY SYSTEMS

EVERPURE-SHURFLO WORLD HEADQUARTERS, 1040 MUIRFIELD DRIVE, HANOVER PARK, IL 60133 USA • FOODSERVICE.PENTAIR.COM
800.942.1153 (US ONLY) • 630.307.3000 MAIN • 630.307.3030 FAX • CSEVERPURE@PENTAIR.COM EMAIL

EVERPURE-SHURFLO AUSTRALIA, 1-21 MONASH DRIVE, DANDENONG SOUTH, VIC 3175 AUSTRALIA
011.1300 576 190 TEL • 011.61.39.562.7237 FAX • AU.EVERPURE@PENTAIR.COM EMAIL

EVERPURE-SHURFLO CHINA, 21F CLOUD 9 PLAZA, NO 1118, SHANGHAI, 200052, CHINA
86.21.3211.4588 TEL • 86.21.3211.4580 FAX • CHINA.WATER@PENTAIR.COM EMAIL

EVERPURE-SHURFLO INDIA, GREEN BOULEVARD, B-9/A, 7TH FLOOR - TOWER B SECTOR 62, NOIDA - 201301
91.120.419.9444 TEL • 91.120.419.9400 FAX • INDIACUSTOMER@PENTAIR.COM EMAIL

EVERPURE-SHURFLO EUROPE, PENTAIR WATER BELGIUM BVBA, INDUSTRIEPARK WOLFSTEE, TOEKOMSTLAAN 30, B-2200 HERENTALS, BELGIUM
+32.(0).14.283.504 TEL • +32.(0).14.283.505 FAX • SALES@EVERPURE-EUROPE.COM EMAIL

EVERPURE-SHURFLO JAPAN INC., HASHIMOTO MN BLDG. 7F, 3-25-1 HASHIMOTO, MIDORI-KU, SAGAMIHARA-SHI KANAGAWA 252-0143, JAPAN
81.(0)42.775.3011 TEL • 81.(0)42.775.3015 FAX • INFO@EVERPURE.CO.JP EMAIL

EVERPURE-SHURFLO SOUTHEAST ASIA, 390 HAVELOCK ROAD, #04-01 KING'S CENTRE, SINGAPORE 169662
65.6768.5800 TEL • 65.6737.5149 FAX • CSEVERPURE@PENTAIR.COM EMAIL

All Pentair trademarks and logos are owned by Pentair, Inc. or its affiliates. All other registered and unregistered trademarks and logos are the property of their respective owners. Because we are continuously improving our products and services, Pentair reserves the right to change specifications without prior notice. Pentair is an equal opportunity employer.